

**Legend**

- Agricultural
- Single Family Residential (No Services)
- Single Family Residential (With Services)
- Designated Development Areas (Mixed Use Commercial)
- Proposed Trails
- Floodplains
- Utility Service Area Limits
- Incorporated Area
- Center Township Boundary

**Note:**  
Proposed land uses are taken from the Boone County Comprehensive Plan. Utility service area limits are taken from the Lebanon Utilities Master Plan.

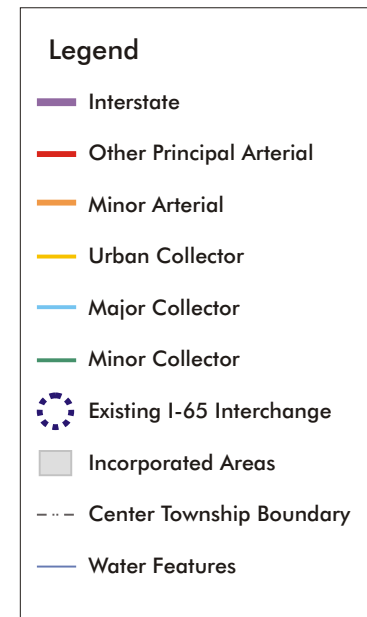
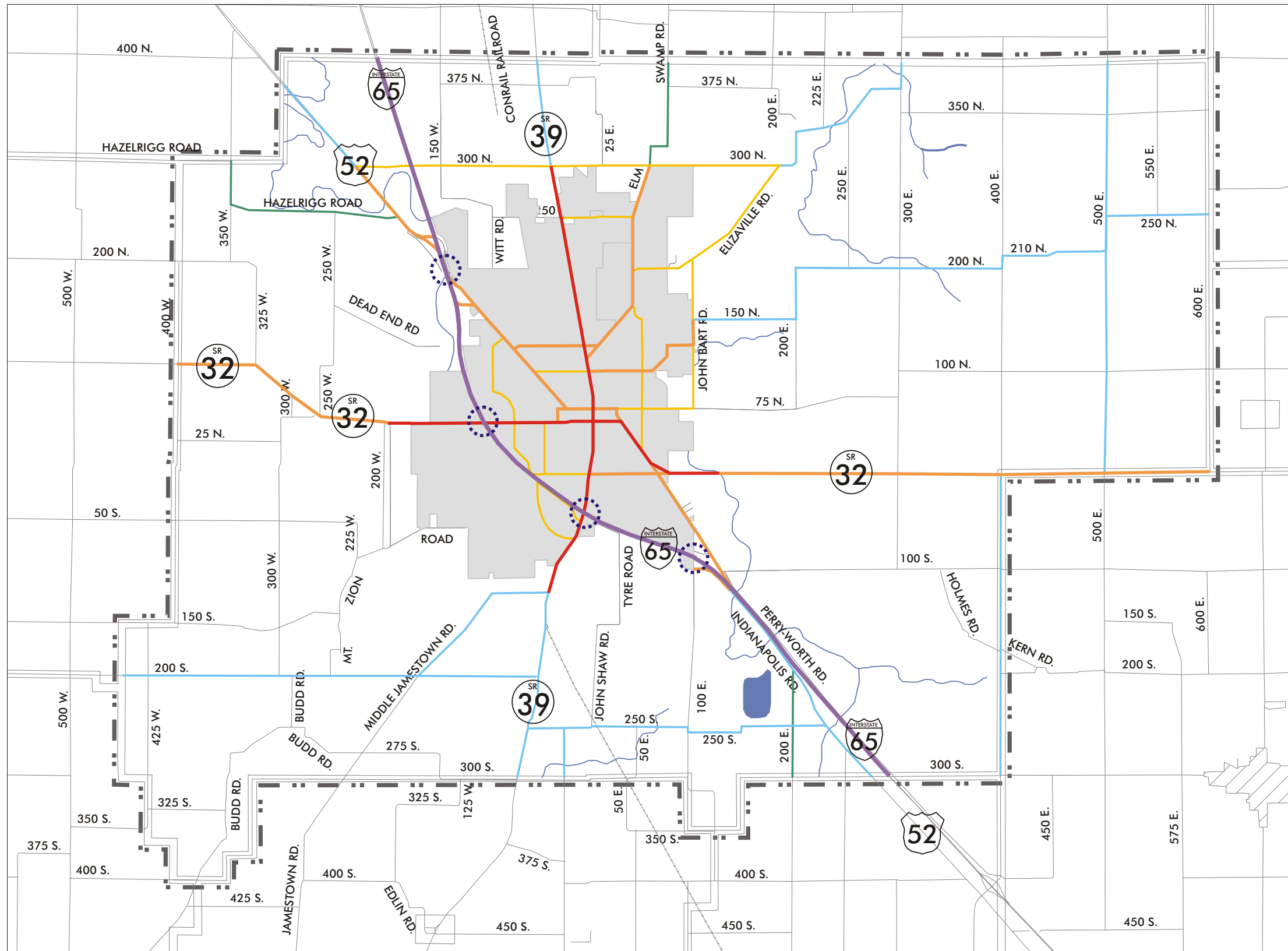

**Note:**  
 Functional Classifications are taken from the INDOT approved Functional Classification Map for Boone County, November 1993.

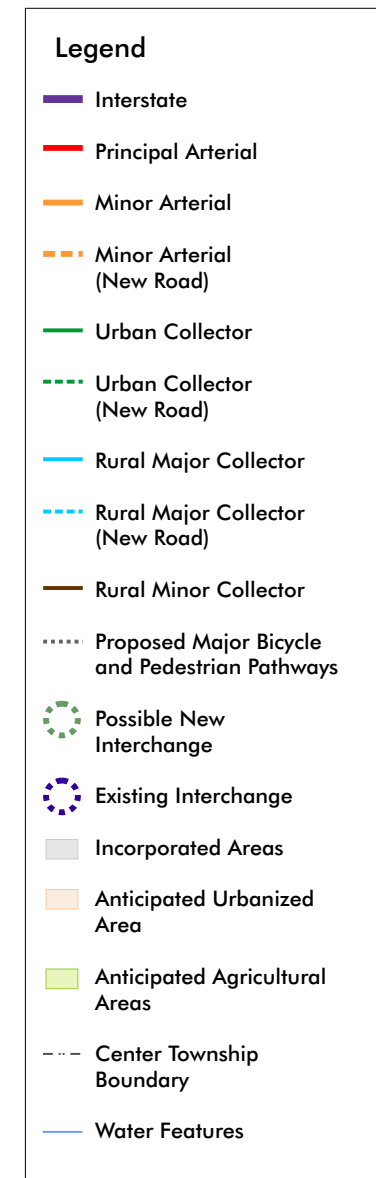
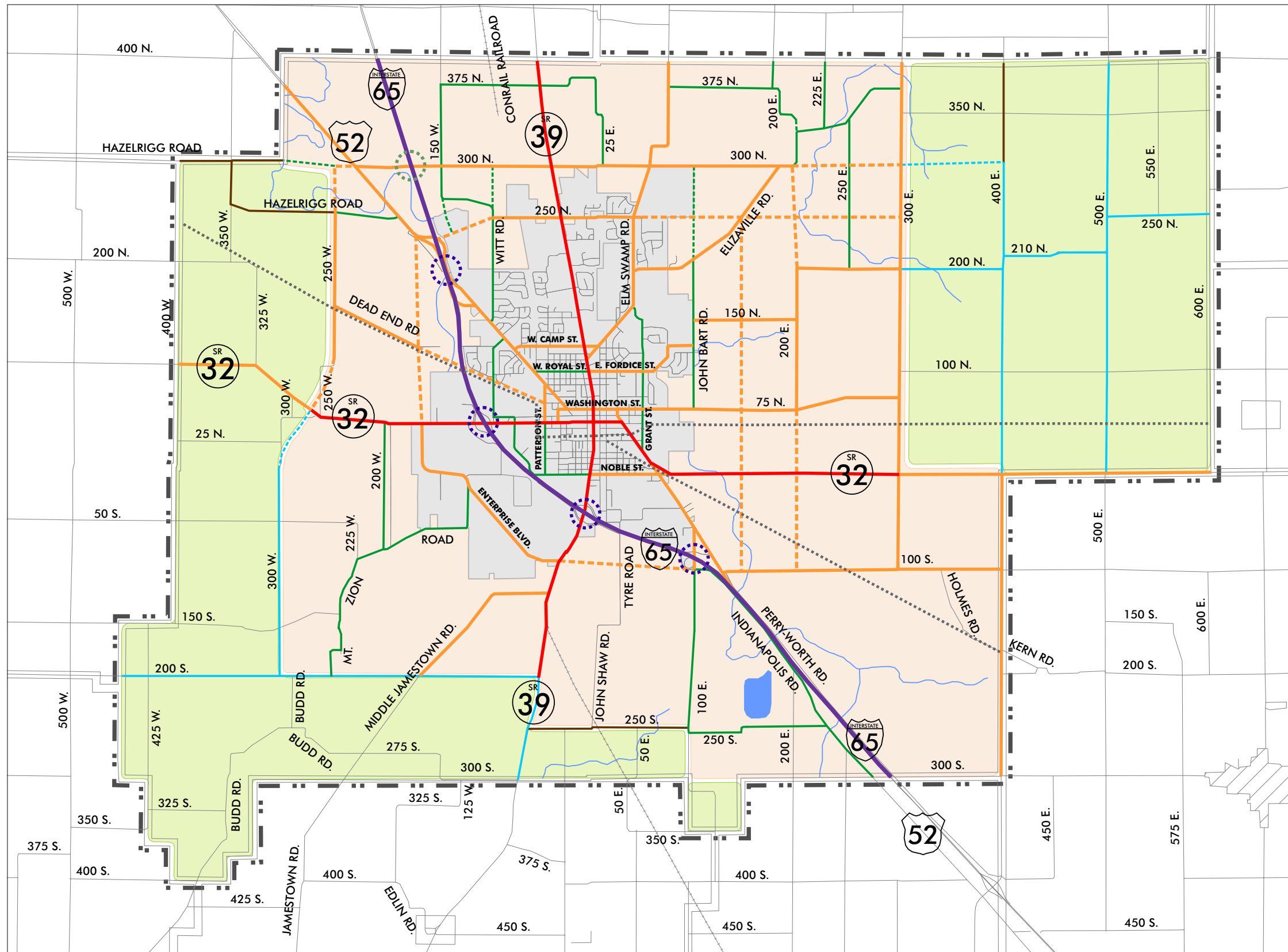

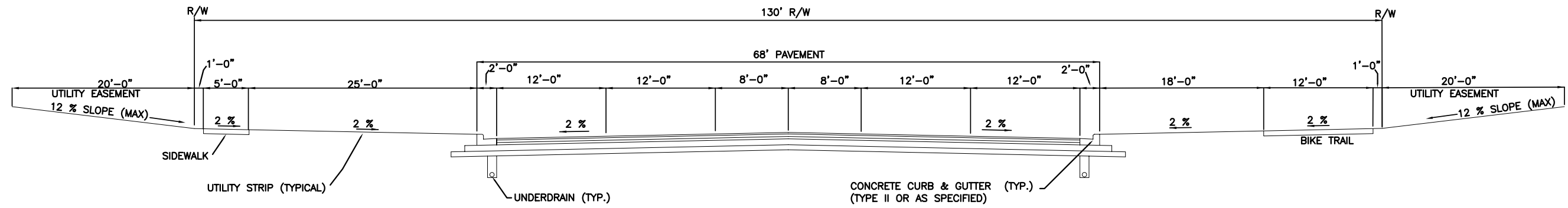

**TYPICAL ARTERIAL ROADWAY  
CROSS SECTION WITH CURB & GUTTER**

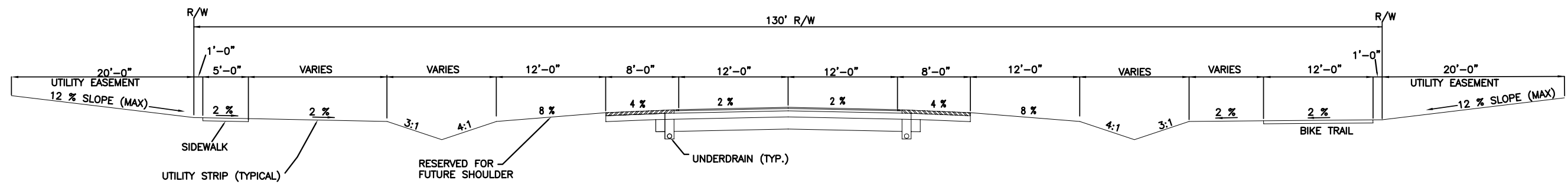

**TYPICAL INTERIM ARTERIAL ROADWAY  
CROSS SECTION WITH SHOULDER**

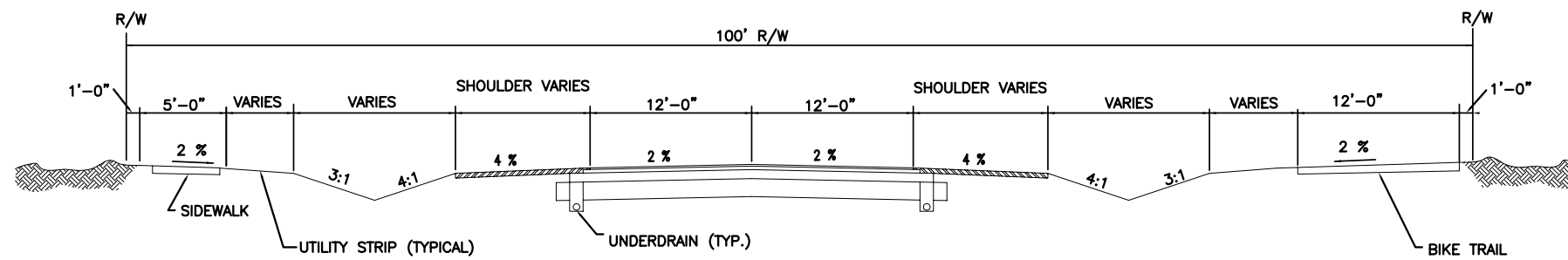

**TYPICAL RURAL COLLECTOR ROADWAY  
CROSS SECTION WITH SHOULDER  
(MAJOR & MINOR)**

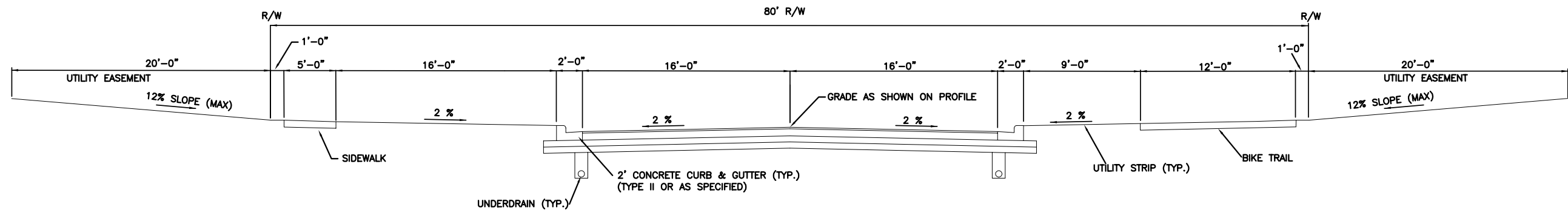

**TYPICAL URBAN COLLECTOR ROADWAY  
CROSS SECTION WITH CURB & GUTTER**

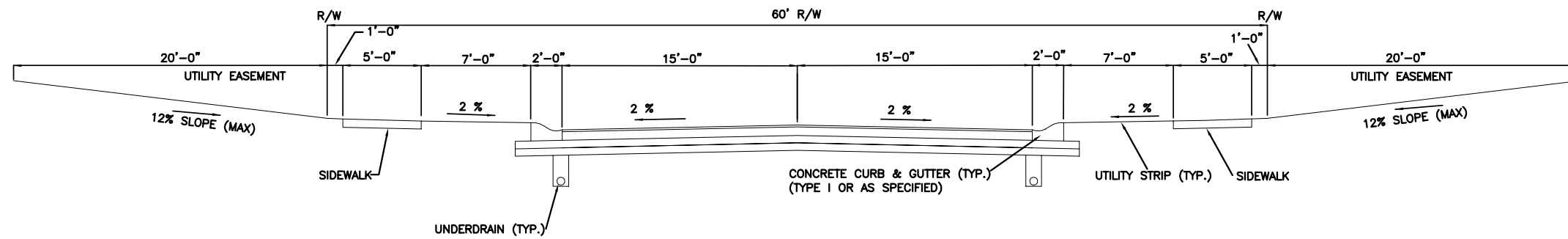

**TYPICAL LOCAL STREET  
CROSS SECTION WITH CURB & GUTTER**